

NDYAG-50xx

NDYG-PL0002-W2N

SINGLE CRYSTAL FIBER AMPLIFIER

Single Crystal Fiber (SCF) amplifiers are the best solution to amplify short pulse lasers in a MOPA configuration since they do not suffer from the strongly aberrant thermal lensing effect that degrades the beam in bulk crystal amplifiers. FiberCryst pioneered the SCF technology and developed the Taranis product benefiting from a unique, patented, thermal management solution for high power pumping. Taranis is an industrial component enabling hassle-free integration in your optical systems: the only requirements are focus of seed signal inside TARANIS and pump/seed alignment.



A Taranis product can amplify a pulsed seed laser from a few kHz to several tens of MHz, or a seed laser from tens of nanoseconds down to a few hundred of femtoseconds, with seed powers ranging from a few hundred mWatts up to tens of Watts.

Taranis products are available in Yb:YAG (Ytterbium) or Nd:YAG (Neodymium) versions.

Nd:YAG Water Cooled Product

CRYSTAL DIMENSION	WATER-COOLED SYSTEM
<ul style="list-style-type: none"> ○ Length : 50 ±1 mm ○ Typical Diameter : 1 ± 0.02mm ○ Typical doping rate: 0.2% at. ± 0.1% 	<ul style="list-style-type: none"> ○ Typical heat transfer coefficient fiber/metallic plate =5W/(cm2.K) ○ Dimensioned for up to 200W pumping ○ Copper water box covered with protective Ni layer

Water cooling should be operated under 5 bars of pressure and between 3 to 4 l/min at 20°C.

Operating temperature: +15°C to +35°C (no condensing water).

Storage temperature: +15°C to +35°C (no condensing water).

DIMENSIONS

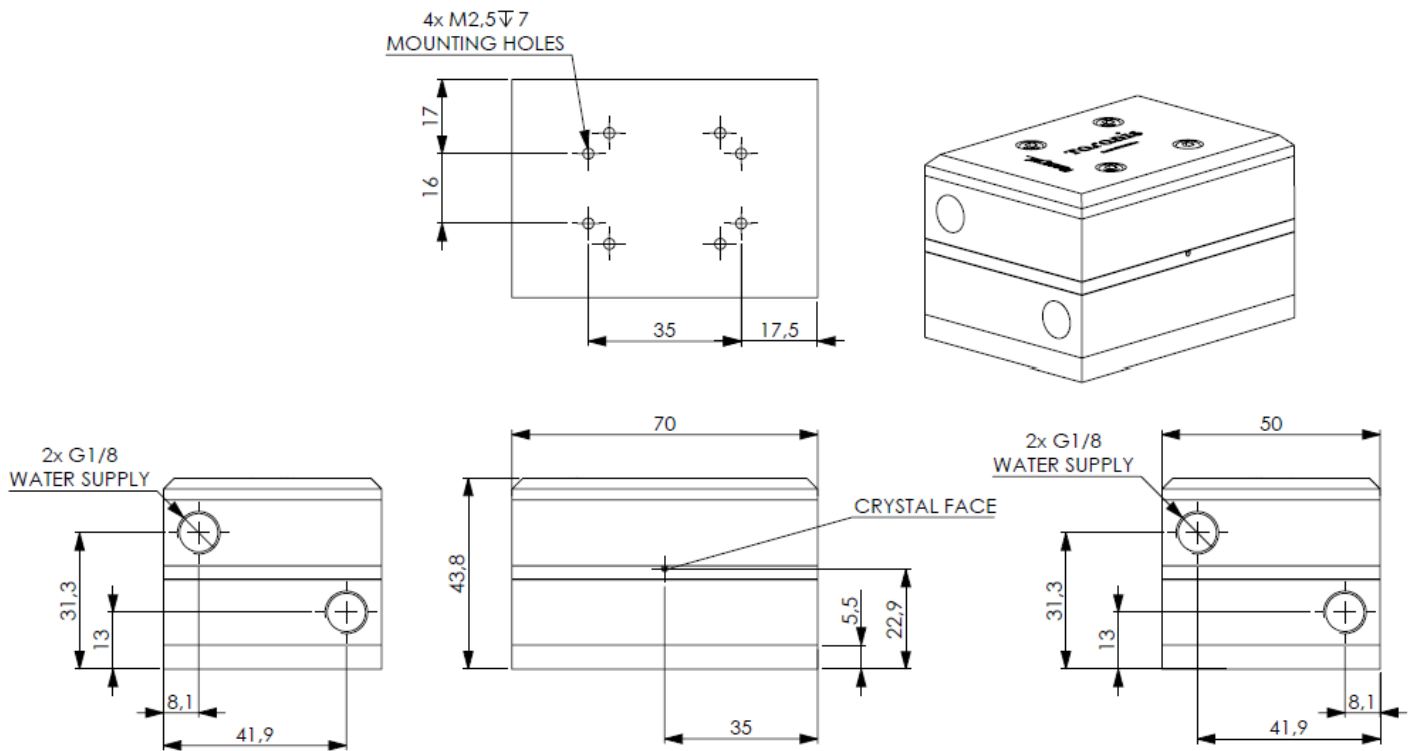

OPTICAL SPECIFICATIONS

Nd:YAG material	Preferred wavelength is 1064nm. See note (1)
Depolarization losses	< 2%. See note (2)
Coating	AR/AR from 808 nm to 1064 nm.
Clear aperture diameter	800 μ m
Max energy density	3 J/cm ² at 1 ns pulse duration
Pump wavelength	808 nm
Max pump power	150 W. See note (3)
Max input pulse duration	Continuous wave
Min output pulse duration	10 ps. See note (4)

(1) For optimum performances, the center wavelength should be at $1064.3 \pm 0,1$ nm and the full width at half maximum (FWHM) lower than 1 nm.

(2) Experimental conditions upon request.

(3) Above 150 W of pump power, contact FIBERCRYST for specific recommendation.

(4) Below 10ps pulse duration, contact Fibercryst.